

Frequently Asked Questions

a) Why can't I get any sound from my Safe2Talk speaker?

Make sure the volume control knob on the Safe2Talk is turned up when connecting or making a call. This is the simplest solution but often is the most correct.

b) Why is the Safe2Talk noisy and distorted?

Some people like to have their phone ring loudly, but this may cause distortion when transferred to the Safe2Talk speaker. If this is a problem for you we recommend, setting up a profile on your phone with lower ringing volumes and keypad tones and activate when using with Safe2Talk. (see your mobile phone user manual for instructions). Avoid having the speaker and microphone pointing towards each other as this may introduce echo or feedback. Have them both face towards the rear of the vehicle with the speaker tilted slightly away from the driver.

c) Why won't my Safe2Talk power up when inserted in the cigarette lighter socket?

Check whether there is 12 volts power to your cigarette lighter by trying to heat the cigarette lighter plunger in the socket. Check that the sockets terminals are not worn or covered in dirt or dust.

d) Am I using the correct connector for my phone?

Safe2Talk is universal providing connectors for most mobile phones on the market. If you change your phone, simply purchase a new connector without having to replace the whole unit.

Troubleshooting Guide

No Power

Check power button is on (i.e. LED light on unit)
Check kit in another car.
Check another item in cigarette lighter.

No Audio

Check arrows match on lead from phone to main unit i.e. > < points meet.
Make sure the volume knob is turned up. (this is a common issue!)
Check privacy button isn't depressed. (i.e. green LED on unit – not red)

People Can't Hear You

Check mic isn't plugged in to ear piece socket in bottom of unit.
Try relocating mic.

Bad Call Quality

Check mic, phone & unit are as far apart as possible.
Check lead is correctly attached to phone.
Please try relocating mic and handset as far away as possible from other electrical devices in vehicle (i.e. the radio)

If you are still experiencing problems with the kit please either:
Return it directly to BlueAnt for testing and replacement of faulty items – please call 1300 669 049 to arrange 'Return Merchandise Authorisation' (RMA) Number , or fill out a warranty form at www.blueant.com.au
OR
Return the Safe2Talk to your place of purchase & the store will be able to return the kit to Blueant for testing & replacement of faulty items.

The BlueAnt Guarantee

BlueAnt warrants the original purchaser of this product and related connectors for a period of 2 years from the date of purchase.

Warranty Terms & Conditions

1. BlueAnt warrants the original purchaser of this product only.
2. BlueAnt will replaced or repair any faulty product provided it has not been misused or abused in any way.
3. Proof of purchase must be supplied to obtain warranty. The warranty is from the date of purchase for no more than twenty four months.
4. Warranties are effective from the proof of purchase date and not from the date of any subsequent repair or replacement.



Blue
ant wireless

Safe2talk

universal plug & go handsfree

High Quality - 2 Year warranty - Rapid Installation

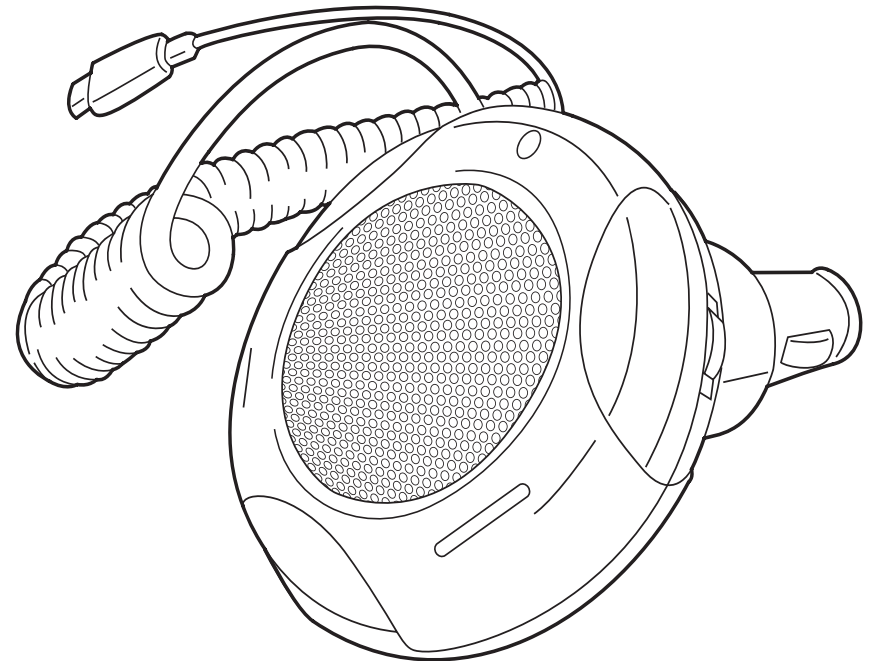

User Guide

www.blueant.com.au

1300 669 049

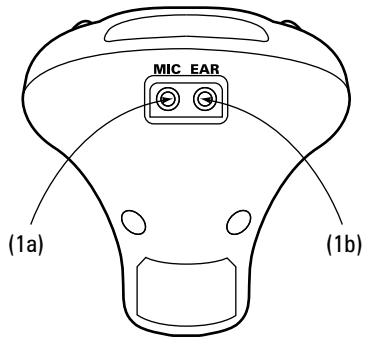
1**Installation**

- Attach the microphone to the speaker unit via the "MIC" socket (1a), located at the base of the unit. (If you wish to use the privacy function, attach an ear piece via the "EAR" socket (1b)).
- Connect the adaptor lead (2a) to the speaker unit lead (2b) making sure to line up the arrows. Insert the adaptor lead connection into the power socket of the phone (2c).

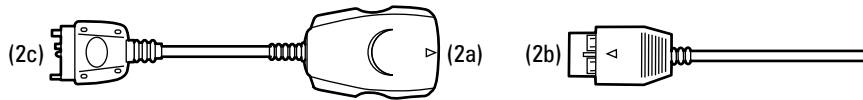
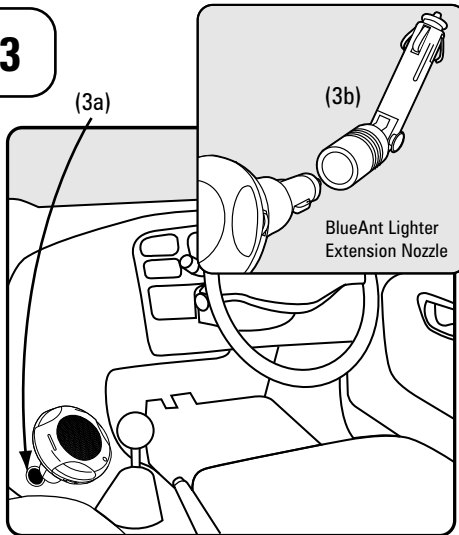
2**3****Connection to Power**

- Connect the power to the cigarette lighter socket (3a).
 - If your cigarette lighter socket is recessed or obscured please use the BlueAnt Lighter Extension Nozzle (3b).
 - Switch your phone back on, and set up an appropriate profile to use the Safe2Talk unit with. This will make your phone usage simpler for future in-car use.
 - Ensure that accessories power is on or your engine is running, then insert the speaker unit into the vehicle's cigarette lighter socket.
 - Ensure that the power is on by pressing the "POWER" button (4a). Once in use the LED indicator will turn green. If the unit is in privacy mode, the LED will glow red.
 - The volume of the ringing tone will be as usual altered in the menu of the phone. The speaker unit volume can be adjusted if necessary by using the volume control (4c).
- Important note** Ensure the volume of the unit is not turned off.

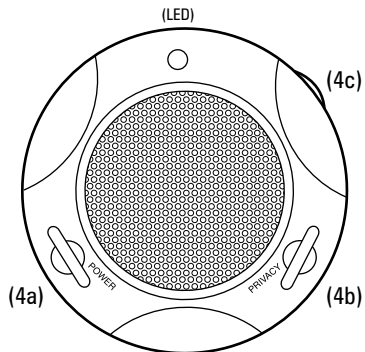
4

- The Privacy Mode (4b) channels the audio through an earpiece diverting it from the speaker unit. To enable Privacy Mode simply press the button whilst receiving a call and ensure that an earpiece is attached to the socket (1b).

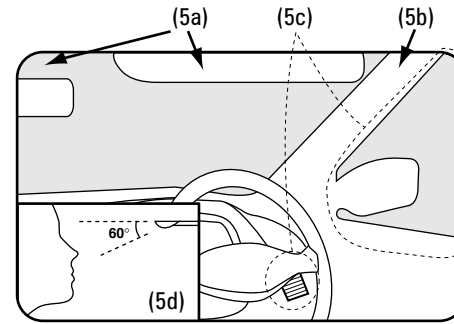
5**Microphone**

- Secure the microphone in one of the suggested positions (5a or 5b).
- Try to locate the microphone at least 80cm from the main unit and approximately 20-60cm from the driver's mouth.
- The microphone is directional and should be mounted according to Inset (5d) to achieve the best performance. Avoiding positions where there may be draught and wind noise, for example near the side window or close to ventilation outlet (5c).
- The best position is usually at the top of the 'A' pillar (5b), and requires the removal of lining (6a) which is quite simple. Ensure there is some slack on the microphone lead (6b) prior to replacing the drivers side 'A' pillar lining when installing the microphone this way.

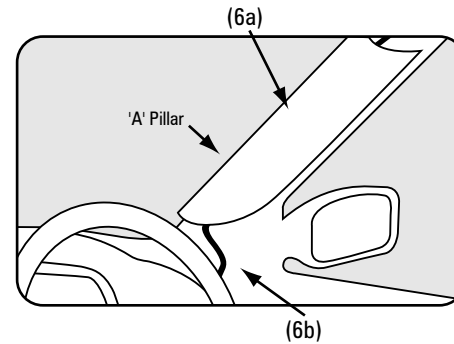
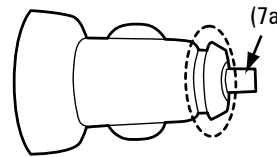
6**7****Important note**

- End cap of the cigarette lighter contains a replaceable 1 Amp fuse (7a). If you remove the end cap be careful not to lose the internal spring. Please ensure cap is secured firmly before use.

8**Installation of Mobile Phone Holder**

- Use the supplied screws to attach holder to dashboard, or alternatively
- Use the supplied double sided bonding tape to secure in position.

9**Making a call**

- Dial desired contact number and press 'call' on your mobile phone, then the audio will be automatically transferred to the Safe2Talk.

To further increase safer mobile phone usage BlueAnt recommends the following when using your hands free car kit:

- Avoid heated or stressful conversations.
- Never send or read SMS messages whilst driving.
- Reduce mobile phone usage in heavy traffic or when driving in bad weather.
- Familiarise yourself with the features of your mobile phone. One touch dialing, auto answer & voice tags, minimise distractions associated with making and receiving calls.

Make a good call and always remember that SAFETY is your number one priority.

